

REMOVAL TYPE NOZZLE

Order form

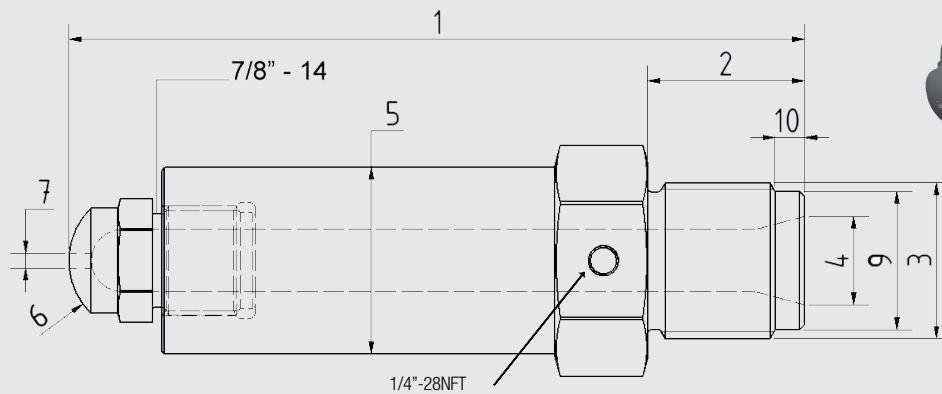
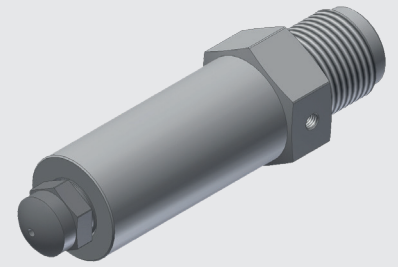

Machine and Model

Injection rate
in cm³/s

(1) Total length

(7) Opening (1.5, 2.5, 3, 4,)

(2) Thread Length

(8) Internal Design

(3) Thread Type
(M36x2 or 1"1/4-12UNF,...)

- Universal (GP)
- Polyamid (NRT)
- ABS (FT1)

(4) Rear opening

(9) Ø relief

(5) Diameter
(25 mm, 38 mm, 50 mm)

(10) Relief length

(6) Radius
(12,7mm, 15mm, 19mm, 35 mm...)

(8) Type

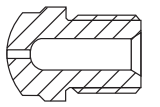
Universel (GP)

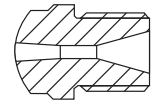
Polyamid (NRT)

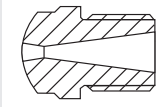
ABS (FT1)



FT1 & NRT : Opening mini : 3mm

- Tip length**
- 38 mm (1)
 - 70 mm (2)
 - 95 mm (3)
 - 127 mm (4)

Length 70, 95 & 127mm are not available in ABS version

(6) Radius

- 35 mm (8)
- 30 mm (R30)
- 19 mm (7)
- 15 mm (6)
- 12,7 mm (5)
- 10 mm (R10)
- 9 mm (9)
- 120° (4)
- 90° (3)
- 70° (1)
- 60° (2)
- Other



- (7) Opening**
- 1,5 mm (I)
 - 2 mm (H)
 - 2,5 mm (J)
 - 3 mm (K)
 - 4 mm (L)
 - 5 mm (M)
 - 5,5 mm (Q)
 - 6 mm (N)
 - 6,5 mm (R)
 - 7 mm (S)
 - 8 mm (O)
 - 9,5 mm (P)
 - Other

GP	1	R15	3
----	---	-----	---

Example: GP1-R15-1
 Universal type (GP) - Tip length 38mm (1) - Radius 15mm - Opening 3 mm